

TIPS ON SELECTING AN ADVANCE CURVE

- Use as much initial advance as possible without encountering excessive starter load.
- Start the centrifugal advance just above the idle rpm.
- The starting point of the centrifugal advance curve is controlled by the installed length and tension of the spring.
- How quickly the centrifugal advance (slope) comes in is controlled by the spring stiffness. The stiffer the spring, the slower the advance curve.
- The amount of advance is controlled by the advance bushing. The bigger the bushing, the smaller the amount of advance.

CENTRIFUGAL ADVANCE CURVE

SELECTING THE ADVANCE SPRINGS

The rate, or how quick the advance comes in is determined by the type of springs which are installed on the distributor. The distributors are equipped with two Heavy Silver springs installed. These will give you the slowest advance curve possible. The parts kit contains two additional sets of springs which can be used to match the advance curve to your particular application.

To change the springs, remove the cap and rotor and use needlenose pliers to remove the springs. Be sure the new springs seat in the groove on the pin.

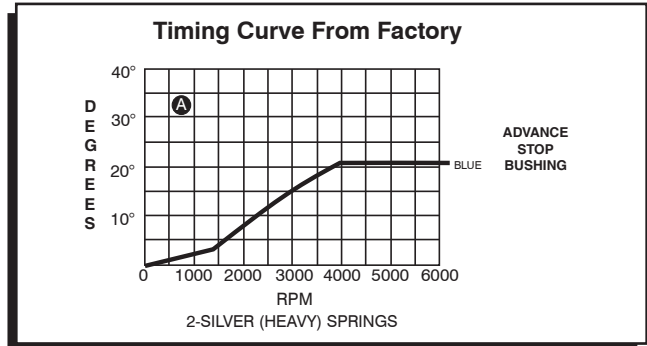

The Factory Equipped Curve.

SPRING COMBINATION	RATE OF ADVANCE
2- Heavy	SLOWEST
1- Heavy	
1- Medium	
1-Heavy	
1-Light	
2- Medium	
1- Medium	
1- Light	
2- Light	

Spring Combination Chart.

SELECTING THE ADVANCE STOP BUSHING

Three different advance stop bushings are supplied in the distributor kit. The distributor comes with a (.340 21°) bushing already installed. If a different amount of centrifugal advance is desired, follow the next procedure to change the bushings. The chart gives the size and approximate degrees for the corresponding bushings.

CHANGING THE ADVANCE STOP BUSHINGS

1. Remove the distributor cap and rotor.
2. Remove the locknut and washer on the bottom of the advance assembly
3. Remove the bushing and install the new one. Install the washer and locknut. Use care not to over-tighten.

BUSHING SIZE	APPROXIMATE CRANKSHAFT DEGREES
.275	28
.310	25
.340	21
.375	18

Advance Stop Bushing Chart.

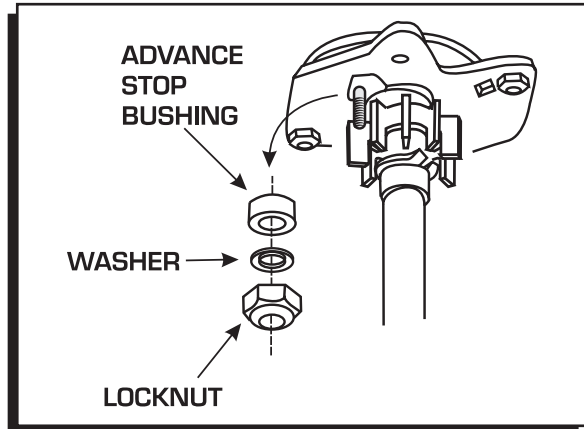

Changing the Advance Stop Bushing.

LOCKING OUT THE CENTRIFUGAL ADVANCE

1. Remove the advance components including the springs, weights and the advance stop bushing from the advance assembly.
2. Remove the roll-pin from the drive gear and remove the gear from the shaft.
3. Slide the shaft two inches out of the housing.
4. Rotate the shaft 180° and insert the advance stop bushing pin into the small hole on the advance plate.
5. Install the locknut and washer to the advance stop bushing pin. This locks the advance in place. Do not over-tighten the locknut.
6. Install the drive gear or retaining sleeve and roll-pin.

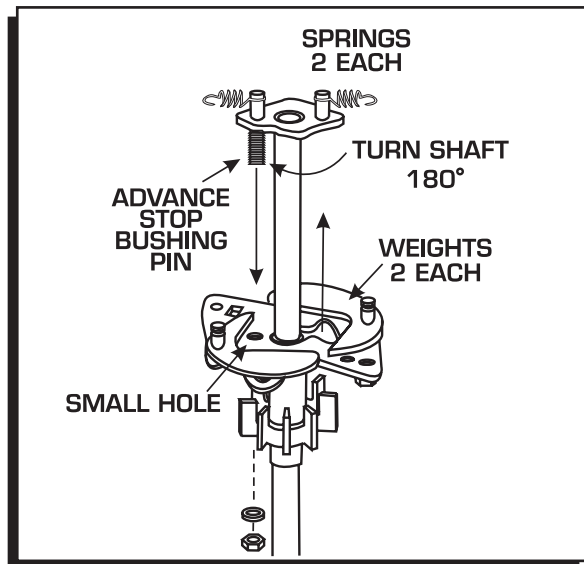

Locking Out the Advance.

INSTALLING THE DISTRIBUTOR

1. Remove the existing distributor cap without disconnecting any of the spark plug wires.
2. With the cap off, crank the engine until the rotor is aimed at a fixed point on the engine or firewall. Note this position by making a mark (Figure 8).
3. Place the distributor cap back on and note which plug wire the rotor is pointing to. MARK THE SPARK PLUG WIRES and remove the distributor cap.
4. Disconnect the wiring from the distributor.
5. Loosen the distributor hold down clamp and slide the clamp out of the way.
6. Lift the distributor out of the engine. Note that the rotor rotates as you lift the distributor out. This is due to the helical cut gear and should be taken into consideration when installing the new distributor.
7. Install the gasket and apply a liberal amount of the supplied lubricant to the distributor gear. (The supplied O-rings can **only** be used if the Chevrolet block has been modified as shown.)
8. Install the distributor making sure that the rotor comes to rest pointing at the fixed mark. If the distributor will not fully seat with the rotor pointing to the marked position, you may need to rotate the oil pump shaft until the rotor lines up and the distributor fully seats.
9. Position and tighten the hold down clamp onto the distributor.
10. Install the distributor cap and spark plug wires one at a time to ensure correct location. A wire retainer is supplied to secure the wires in place. Align the mounting bosses and use the supplied 1.5" self-tapping Phillips screws to hold the retainer in place.

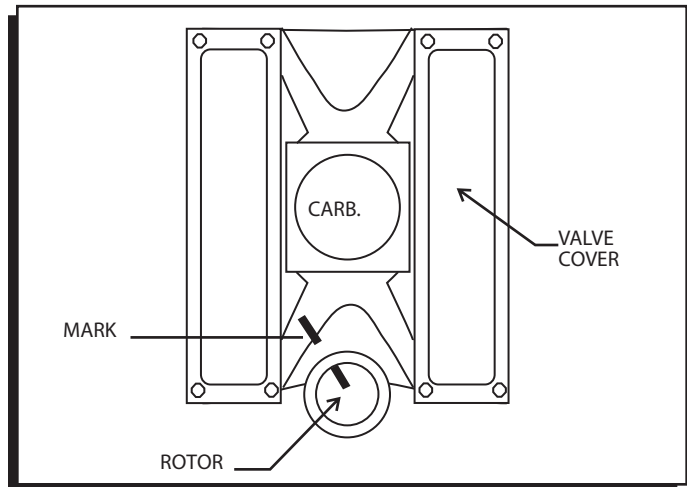

Marking the Rotor Location.

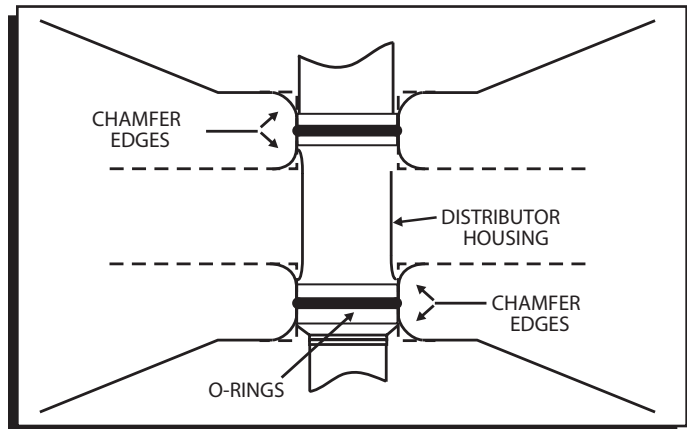

Modified Chevy Block for use with O-Rings.

WARNING: High voltage is present on the coil terminals. Do not touch the terminals or coil tower when the engine is cranking or running.

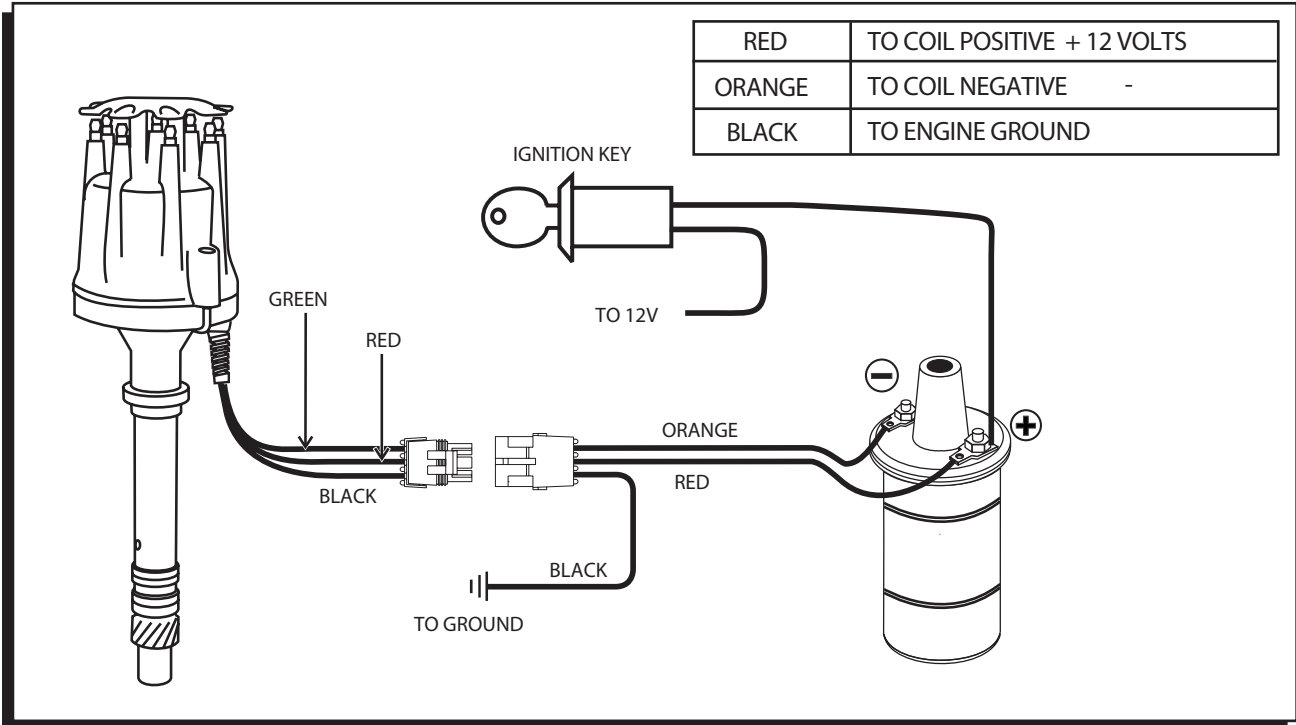

Wiring the Marine Ready-to-Run Distributor.

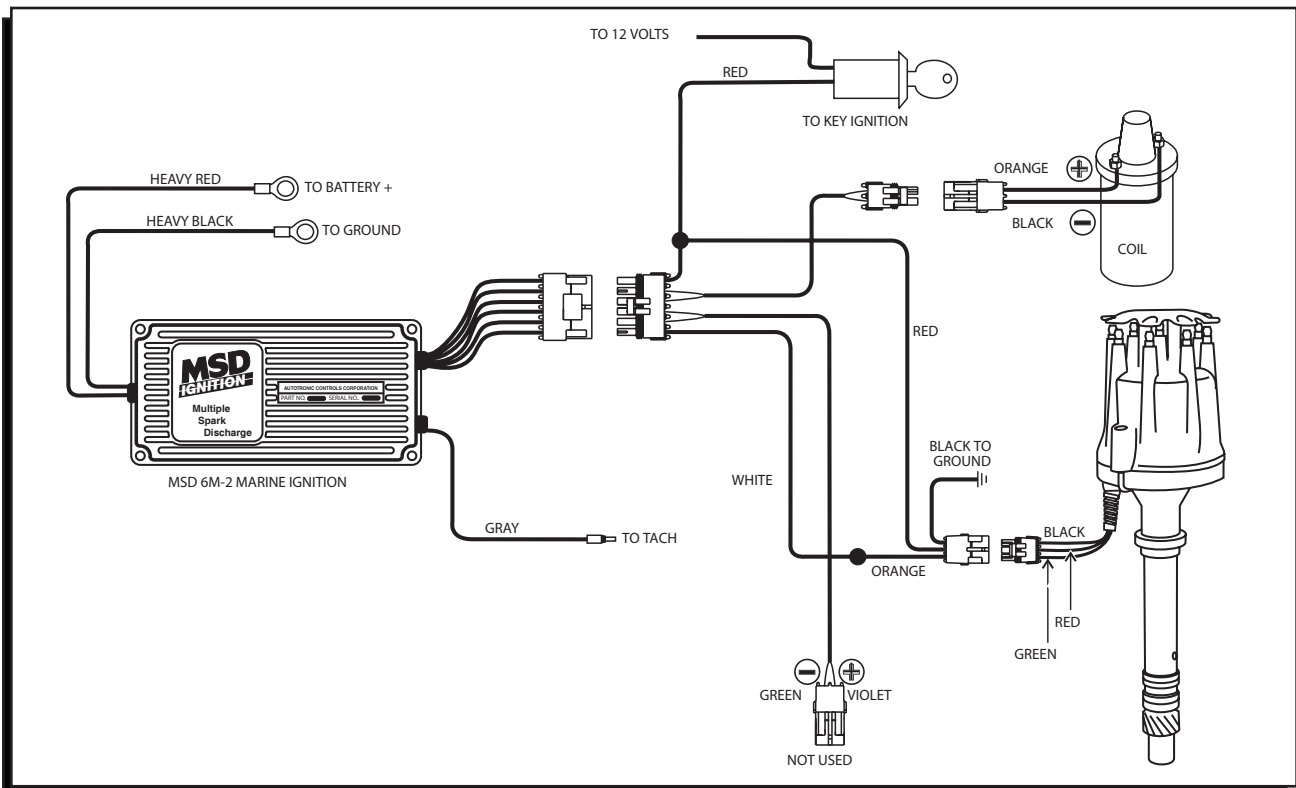

Connecting the Marine Ready-to-Run Distributor to a 6M-2 Ignition Control.

Basic Module Trigger Hookup

